



# Installer Training and Certification Overview

# Outline of This Presentation

---

- ✚ The Need for a Training Program
- ✚ The History of the Program
- ✚ Details of the Training Program
- ✚ The Certification Process

# The Need for a Training Program

- Proper product installation has been an issue to manufacturers for a number of years.
  - Complaints owners have about air/water infiltration.
  - Complaints about window and door operation.
  - Complaints about condensation and sound resistance.
  - Damage caused by improper handling and storage.

**Fact:** Manufacturers spend hundreds of thousands of dollars in field service costs every year fixing these problems.

# The Need for a Training Program

- Proper product installation has been an issue to the Government and Building Industry
  - Due to the increase in energy consumption and the lack of available energy.
  - Realization that there is a lack of coordination between trades.
  - Understanding of the damage due to improper installation.
  - Realization that standards for installation were non-existent.
  - It costs much more to produce energy than it does to conserve it.

**Fact: Millions of BTU's of energy are wasted every year. Millions of dollars are awarded through litigation as a result of faulty installation.**

# The History of the Program

- Several Entities of the Government Were Involved
  - BETEC, an arm of the DOE, intended to set up a training and certification program for window/door installers.
  - BETEC worked through ASTM to develop a standard practice for window/door and skylight installation.
  - BETEC studied the concept of training and certification but never actually started a program.

Fact: AAMA realized that their members had a stake in what was being proposed by the government and determined that this might be an important service for its members and their customers.

# The History of the Program

## ■ The ASTM Standard Installation Practice

- ASTM worked for over five years to develop an installation standard for windows/doors and skylights. ASTM E 2112
- The installation standard was officially approved by the ASTM body on April 1st 2001.
- InstallationMasters™, through many committee members worked through the ASTM consensus process to develop the standard.

**Fact:** A standard is great to have, but we need to educate the installer and others about what that standard means. Standards read like specs!

# Details of the Training Program

- The following subject matter is covered in the first day of training. . .
  - Introduction
  - Design Considerations
  - Types of Windows
  - Types of Doors
  - Accessory Items/Features
  - Performance Requirements
  - Site Inspections
  - Codes/Standards/Specifications
  - Manufacturer's Instructions
  - Measuring and Ordering
  - Inspection and Storage
  - Material Selection and Use
  - Preparing the Opening for Replacement
  - Replacement Window Installation

# Details of the Training Program

- The second day of training includes...
  - New Construction Installation
  - Bay, Bow and Garden Windows
  - Combination Window Installation
  - Specially Shaped Windows
  - Block Frame Door Installation
  - Mounting Flange Door Installation
  - Screen Installation
  - Final Cleaning
  - Quality Control
  - Product Maintenance
  - Review of the Glossary
  - Review of Abbreviations
  - Review of Acronyms

# Details of the Training Program

- The materials used during the training program are ...
  - A 360+ page training manual, fully illustrated with text and graphics covering numerous installation techniques.
  - A 21 segment installation video, developed to show each of the installation practices illustrated in the manual.
  - A PowerPoint presentation that instructors use to maintain focus on the most important aspects of the training.
  - A set of hand samples for demonstration purposes.

# Details of the Training Program

- Let's review some examples of the training content found in Chapter 2 "Design Considerations".

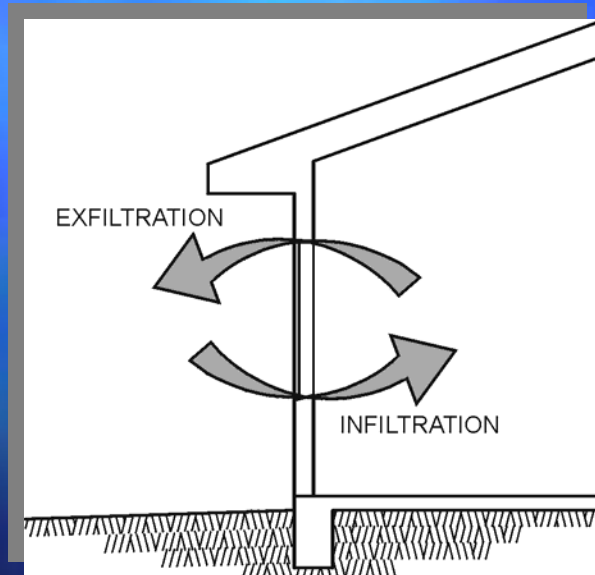

We review what causes air leakage and how to reduce it.

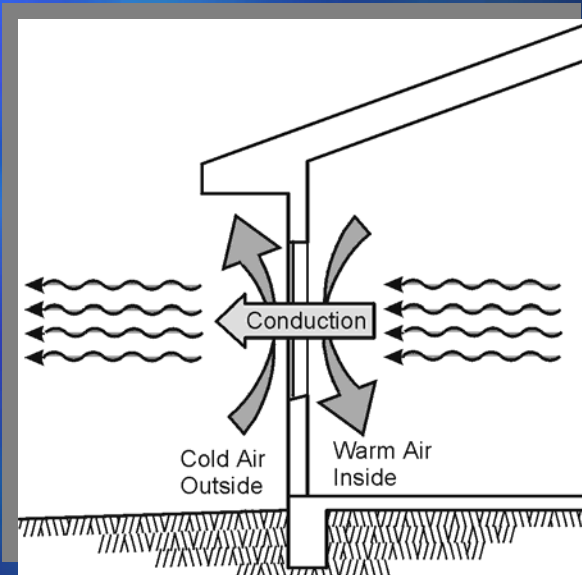

We review the causes of conduction & convection and how to reduce it.

# Details of the Training Program

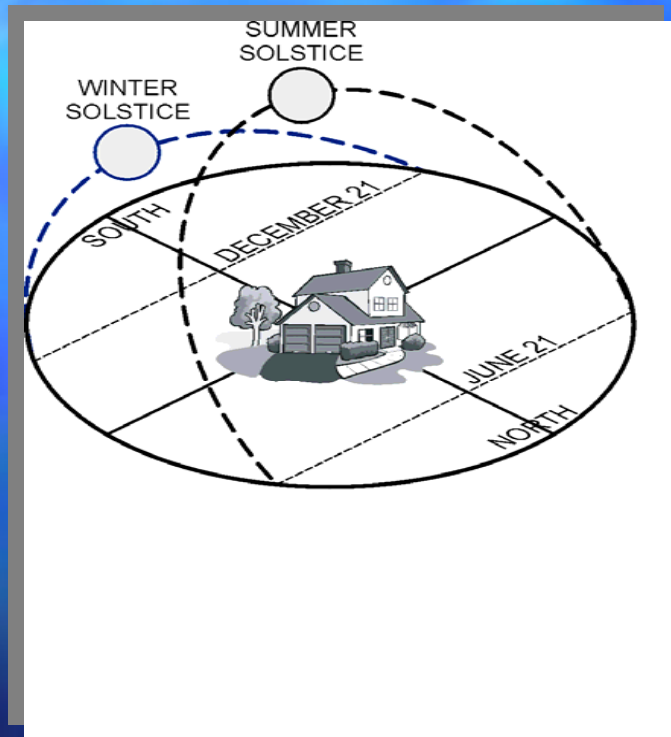

We discuss solar heat gain radiation from the sun and how the exposure changes based on the various seasons.

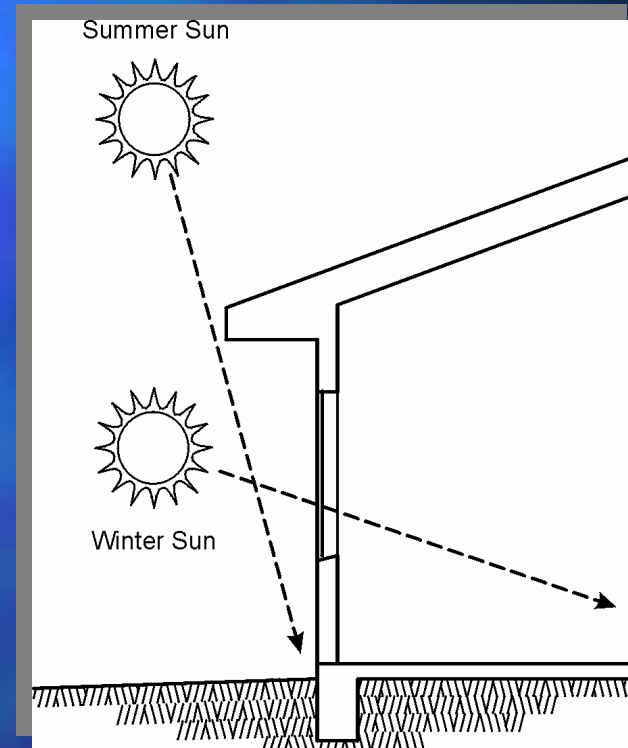

We review the effects of sun exposure and how to reduce solar heat gain.

# Details of the Training Program

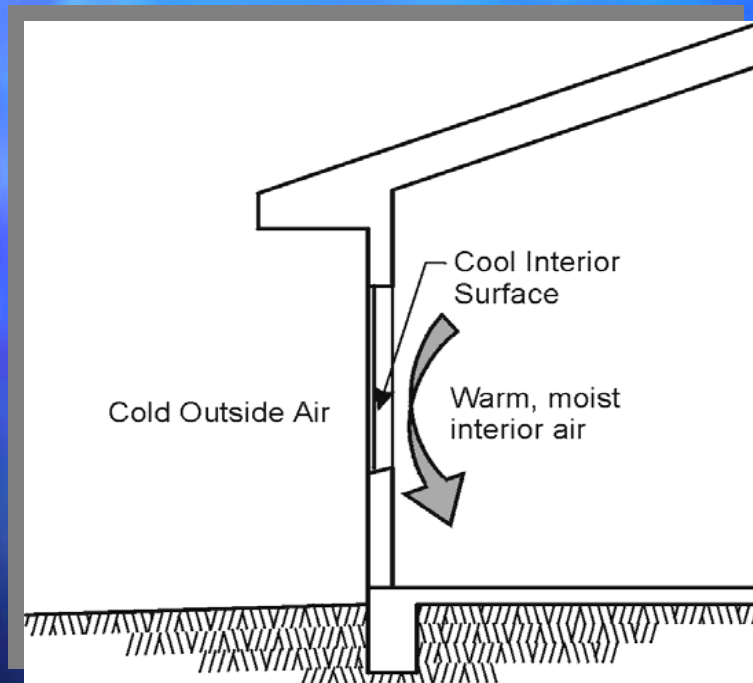

We discuss the causes of condensation and how to reduce it.

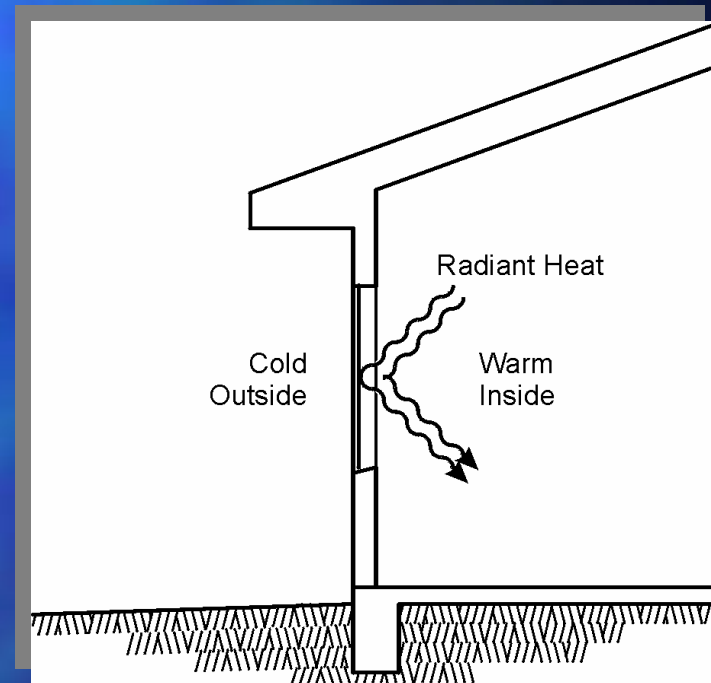

We review the various types of glazing and how to select glass for performance.

# Details of the Training Program



National Fenestration  
Rating Council

**CERTIFIED**

## World's Best Window Co.

**Millennium 2000+ Casement**  
CPD#000-x-000

Vinyl-Clad Wood Frame • Double Glaze  
Argon Fill • Low E + Solar Control Coatings

### ENERGY Performance

- Energy savings will depend on your specific climate, house and lifestyle
- For more information, call 1-800-123-4567 or visit NFRC's web site at [www.nfrc.org](http://www.nfrc.org)

Technical Information			
<b>Res</b>	U-Factor	<b>.32</b>	Solar Heat Gain Coefficient
		<b>.45</b>	Visible Transmittance
<b>Non-Res</b>		<b>.31</b>	<b>.45</b>
		<b>.60</b>	

Manufacturer stipulates that these ratings conform to applicable NFRC procedures for determining whole product energy performance. NFRC ratings are determined for a fixed set of environmental conditions and specific product sizes.



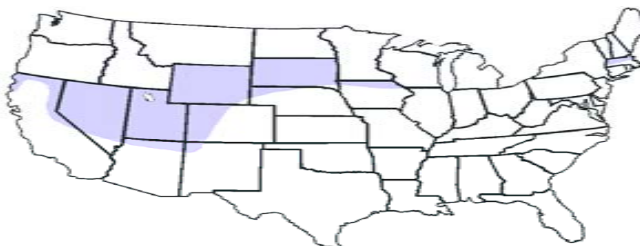

- Northern Zone—Mostly Heating
- Central Zone—Heating and Cooling
- Southern Zone—Mostly Cooling

Energy Star Window Requirements		
Climate Region	Max U-Factor	Max SHGC
Mostly Heating	0.35	
Heating and Cooling	0.40	0.55
Mostly Cooling	0.75	0.40

We discuss temporary window labels and product testing and certification to meet compliance with energy performance standards.

# Details of the Training Program

 MEMBER	QUALITY CONTROL & TESTING <b>AAMA CERTIFICATION PROGRAM</b> ACCREDITED BY: AMERICAN NATIONAL STANDARDS INSTITUTE VALIDATOR: ALI® Mfr: XXXXXXXXXXXXXXXXXXXX Code: XXX-1	This product has been rated in accordance with: ANSI/AAMA/NWDA 101/I.S.2-97 <b>HS-R20 120 X 59</b> Series: 2600 P.L. # 056-003
---	---	---

We review window performance rating systems.

<b>WARNING:</b>	Do not leave small children unattended when windows are open or unlocked. Screens are easily removed from the inside and are not intended as a safety restraint.
-----------------	--

	<b>WARNING:</b> Screen will not stop child from falling out of window. Keep child away from open window.
---	--

We discuss child safety and the limitations of screens when used in windows.

# Details of the Training Program

- Let's review some examples of the training content found in Chapter 3 "Components and Materials".

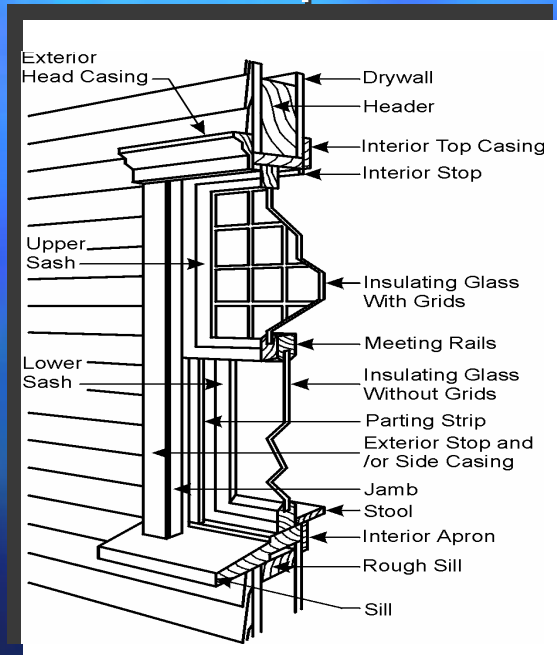

We review the various components and materials found in existing window openings.

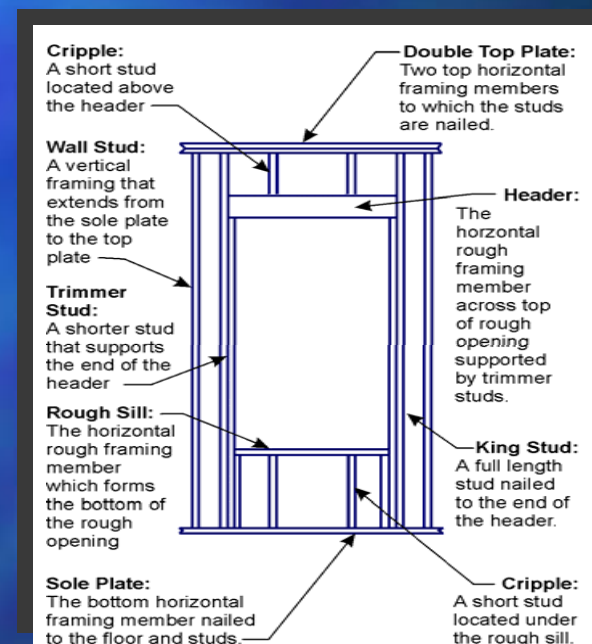

We review the various framing members found in rough frame construction

# Details of the Training Program

- Let's review some examples of the training content found in Chapter 4 "Types of Windows".

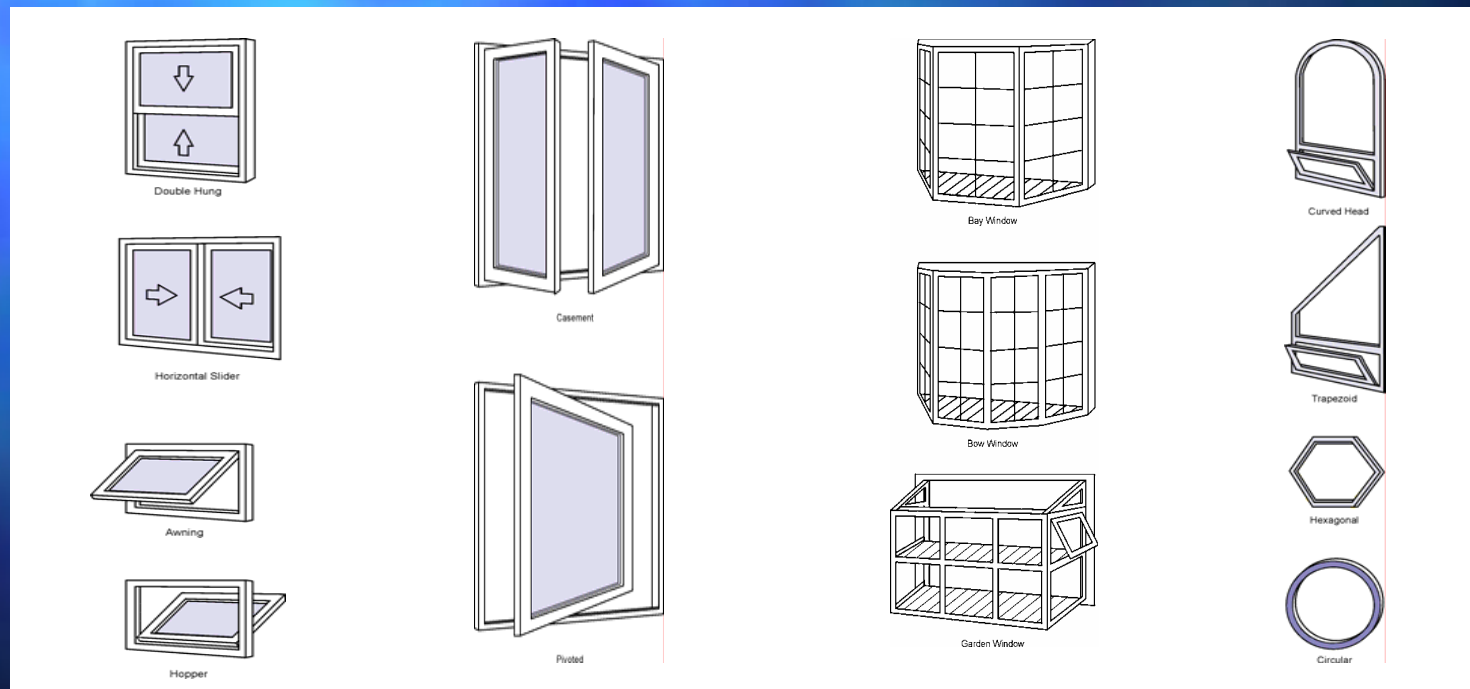

We review the various types of windows used in residential and light commercial construction.

# Details of the Training Program

- Let's review some examples of the training content found in Chapter 5 "Types of Doors".

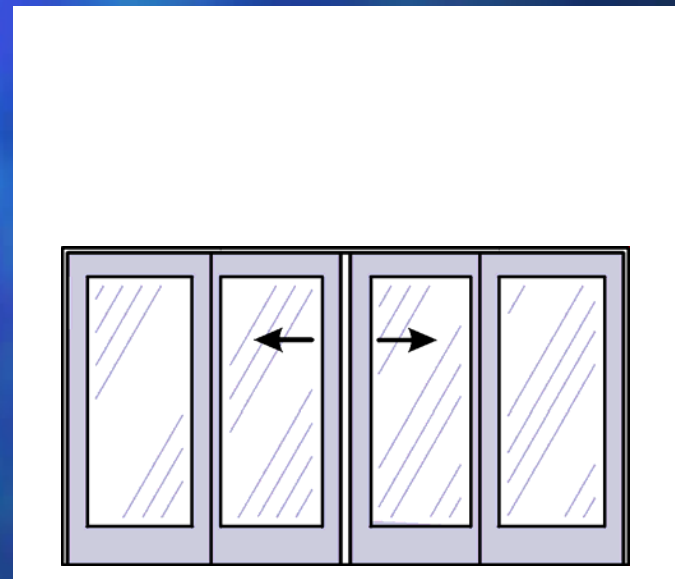
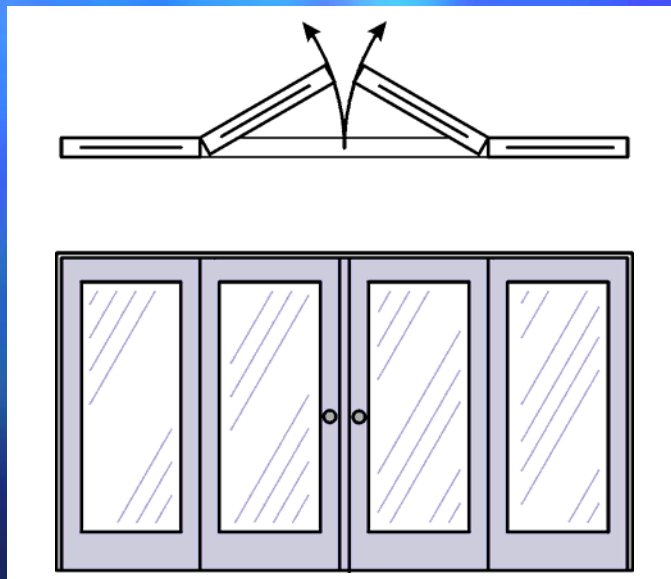

We review the various types of doors found in residential and light commercial construction.

# Details of the Training Program

- Let's review some examples of the training content found in Chapter 7 "Performance Requirements".

Window and Door Classes	Minimum Design Pressure (PSF)	Minimum Structural Test Pressure (1.5 × DP) (PSF)	Minimum Water Resistance Test Pressure (PSF)
(R) Residential	15	22.5	2.86
(LC) Light Commercial	25	37.5	3.75
(C) Commercial	30	45.0	4.50
(H) Heavy Commercial	40	60.0	6.00
(AW) Architectural	40	60.0	8.00

We review the various performance requirements for window and door products.

# Details of the Training Program

- Let's review some examples of the training content found in Chapter 8 "Site Inspection".

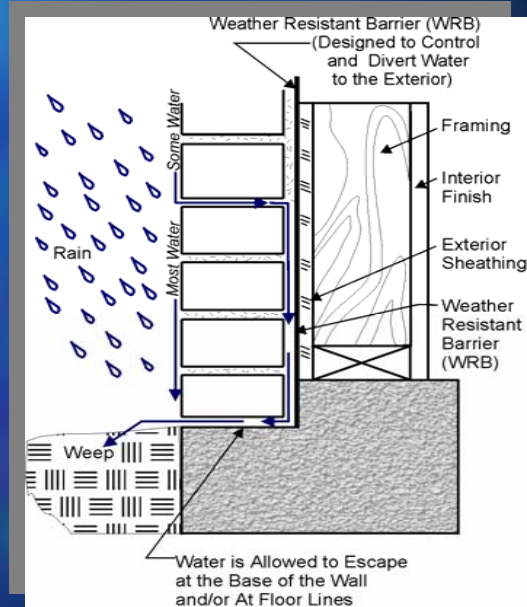
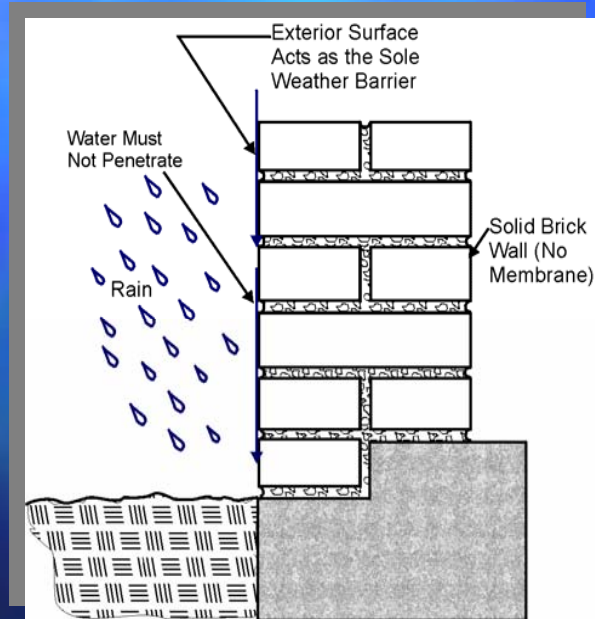

We look at the various types of wall assemblies, including the Surface Barrier System and Membrane/Drainage Wall System and what they mean to the installer.

# Details of the Training Program

In Chapter 8 we also review several sections on...

- Health and Safety Inspection  
(Lead Based Paint/Asbestos-Containing Materials/Hazardous Chemicals)
- Equipment Safety  
(Ladders, Scaffolding, Tools, Respirators, Job Site Safety)
- Site Inspections  
(Protecting Existing Materials & Handling Construction Deficiencies)

We thought it important to cover the health and safety of both the installer and the persons visiting the job site. Safety was the #1 issue for the Committee!

# Details of the Training Program

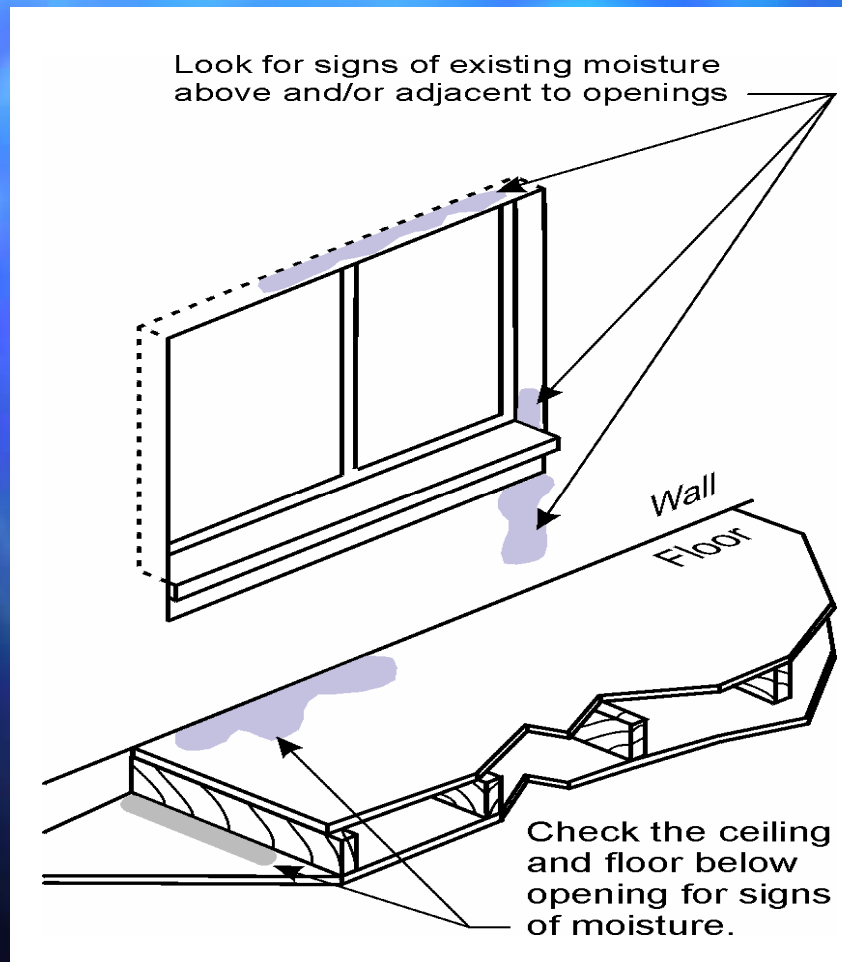

We cover site inspection of the existing openings and how to look for signs of water penetration or damage.

This is critical when installing new windows into existing openings!

# Details of the Training Program

## Chapter 9 Includes Codes, Standards and Specifications

- Where do building codes come from?  
(Review of National/Regional/Local Codes and the Home Rule Doctrine)
- How are standards developed?  
(How do AAMA, ASTM, ANSI, SIGMA, AND NFRC work and why? )
- Review of Agencies/Specifications involved in our industry.  
(Consumer Product Safety Commission, Occupational Safety and Health Administration & Americans With Disabilities Act)

# Details of the Training Program

Chapter 9 also includes...

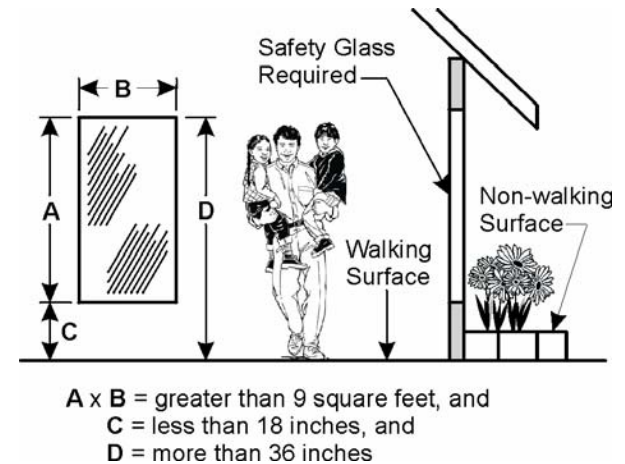
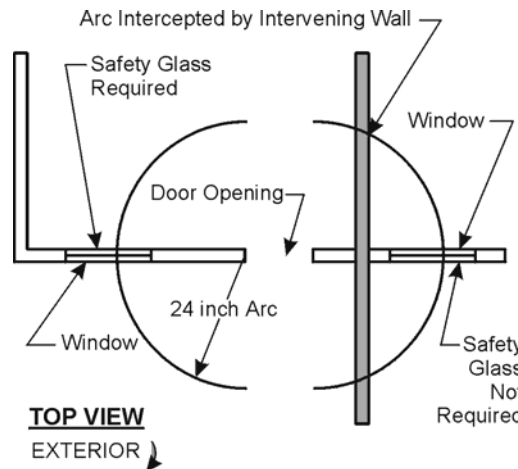
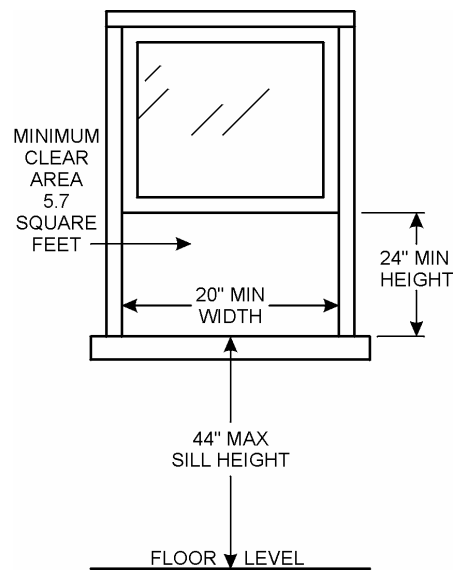

Emergency Egress and Safety Glazing Requirements for Windows and Doors

# Details of the Training Program

Chapter 11 “Measuring and Ordering” includes subjects like...

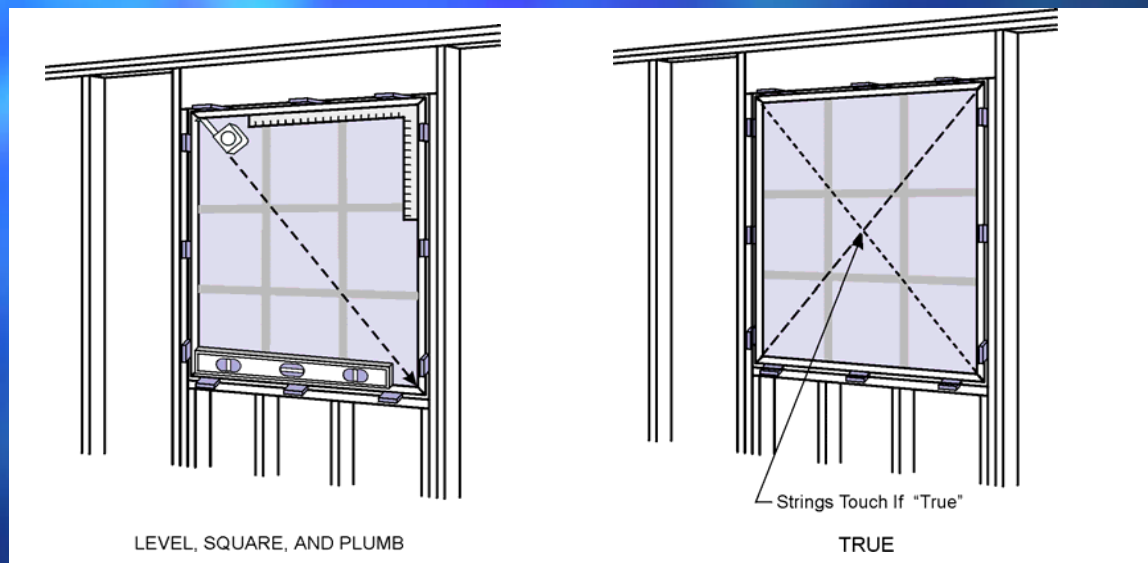

Measuring for width, height and square, and checking for level, plumb and true!!!  
Fact: This part of the training is based on the most common complaints.

# Details of the Training Program

Chapter 13 "Material Selection and Use" covers the use of materials in the field like...

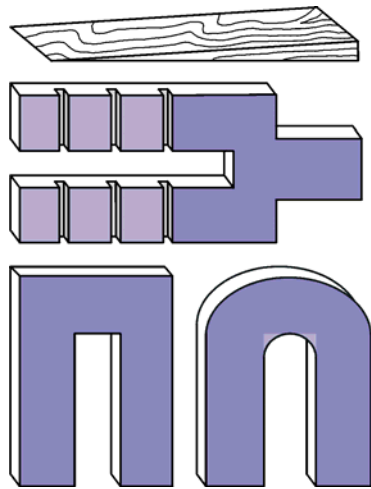

Shims

Sealant

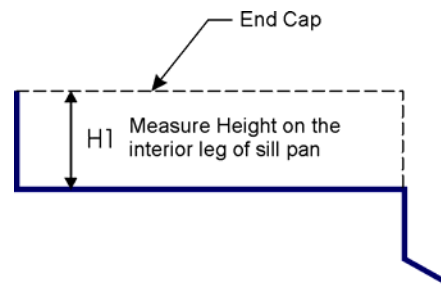

Sill Pans

Fasteners

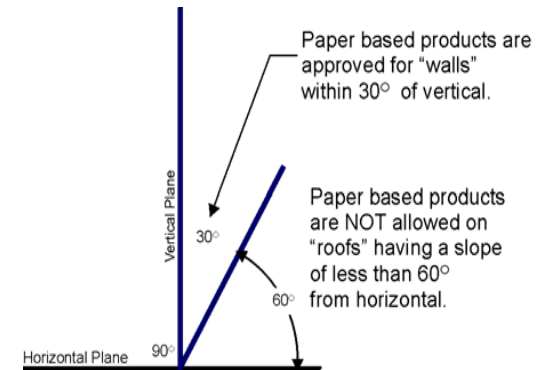

Flashing

Insulation

# Details of the Training Program

Chapter 14 "Preparing the Opening for Replacement" starts the Installation Training portion of the program.

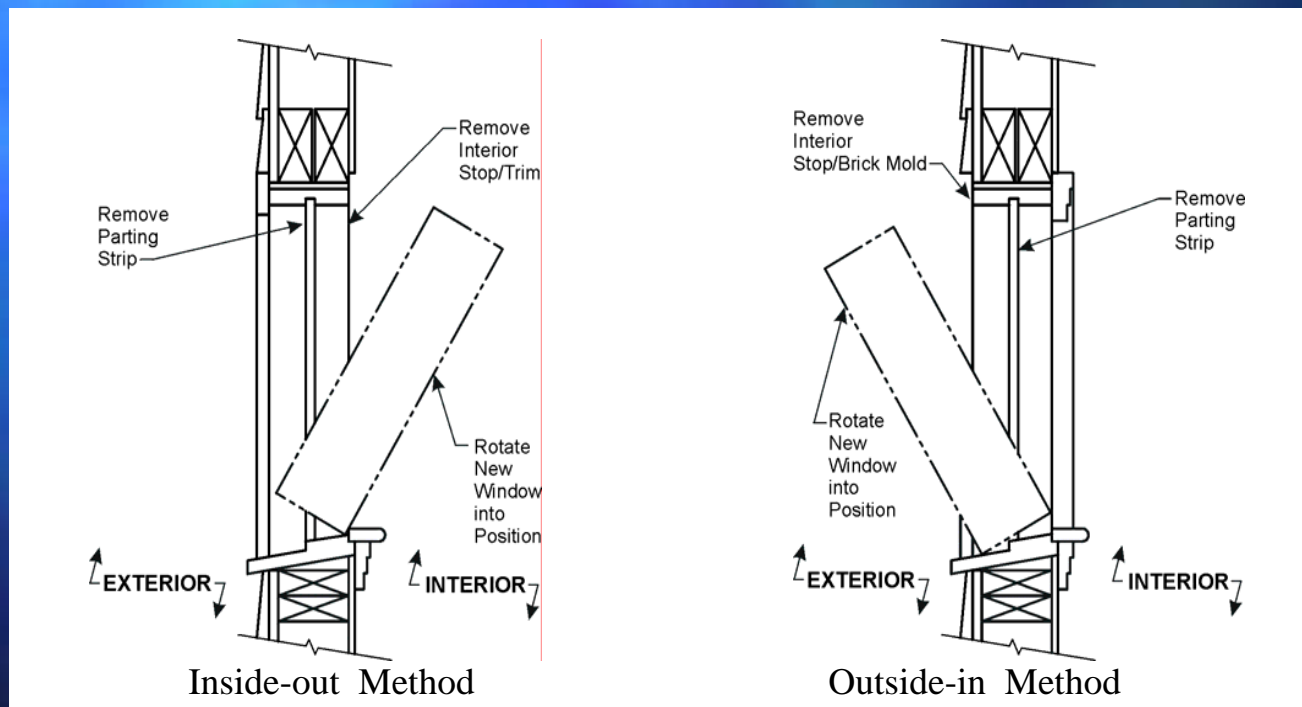

Planning for removal of products from existing openings to allow for replacement.

# Details of the Training Program

## Chapter 15 "Replacement Window Installation" covers...

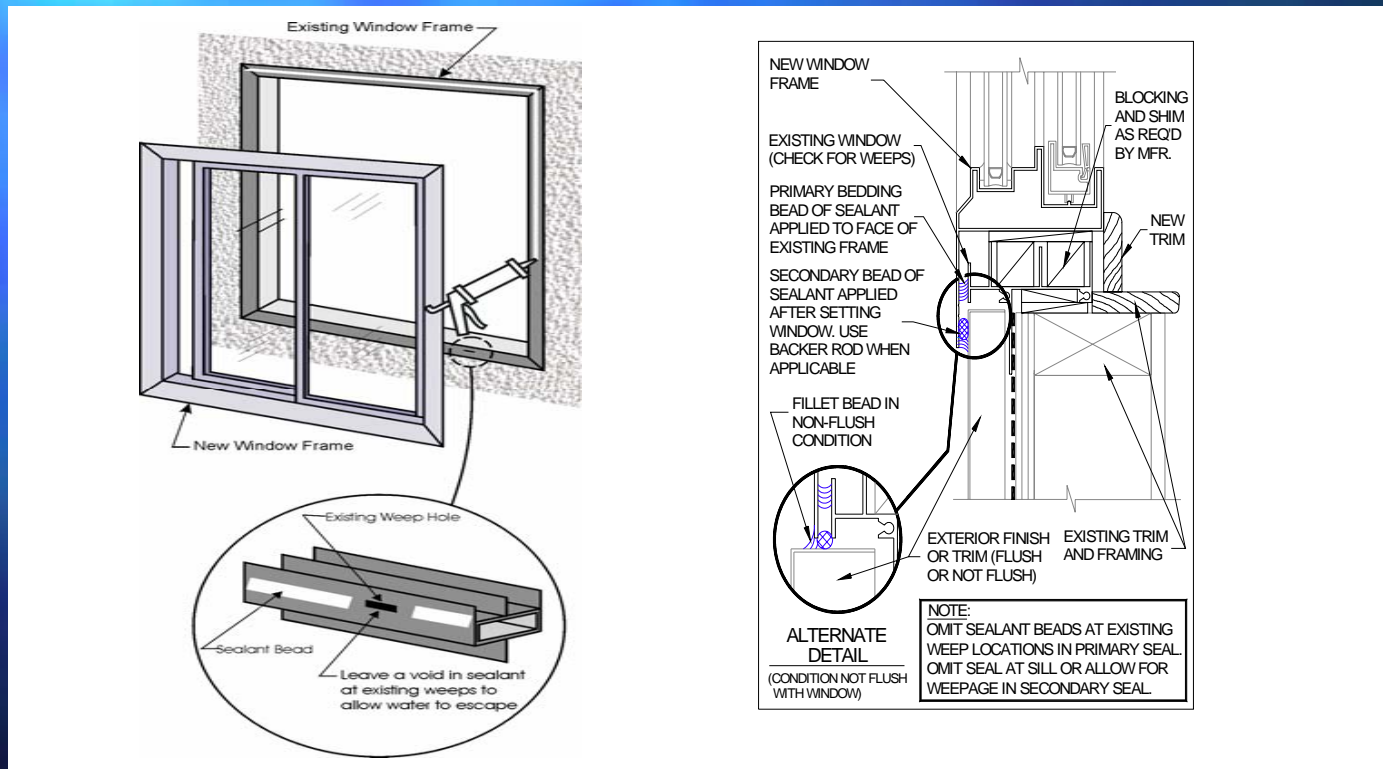

The installation processes recommended for replacement windows.

# Details of the Training Program

Chapter 16 “New Construction Installation” covers...

	A	A1	B	B1
Weather Barrier Applied (First) Prior to Window		✓		✓
Sill Flashing Applied Prior to Window Installation	✓	✓	✓	✓
Jamb Flashing Applied to Opening (Before) Window			✓	✓
Window Set In Place (With Sealant on Back of Flange)	✓	✓	✓	✓
Jamb Flashing Applied w/ Sealant (After) Window	✓	✓		
Head Flashing Applied After Window Installation	✓	✓	✓	✓
Weather Barrier Applied After Window	✓		✓	

The various installation methods recommended for new construction.

# Details of the Training Program

Chapter 16 provides step by step instructions...

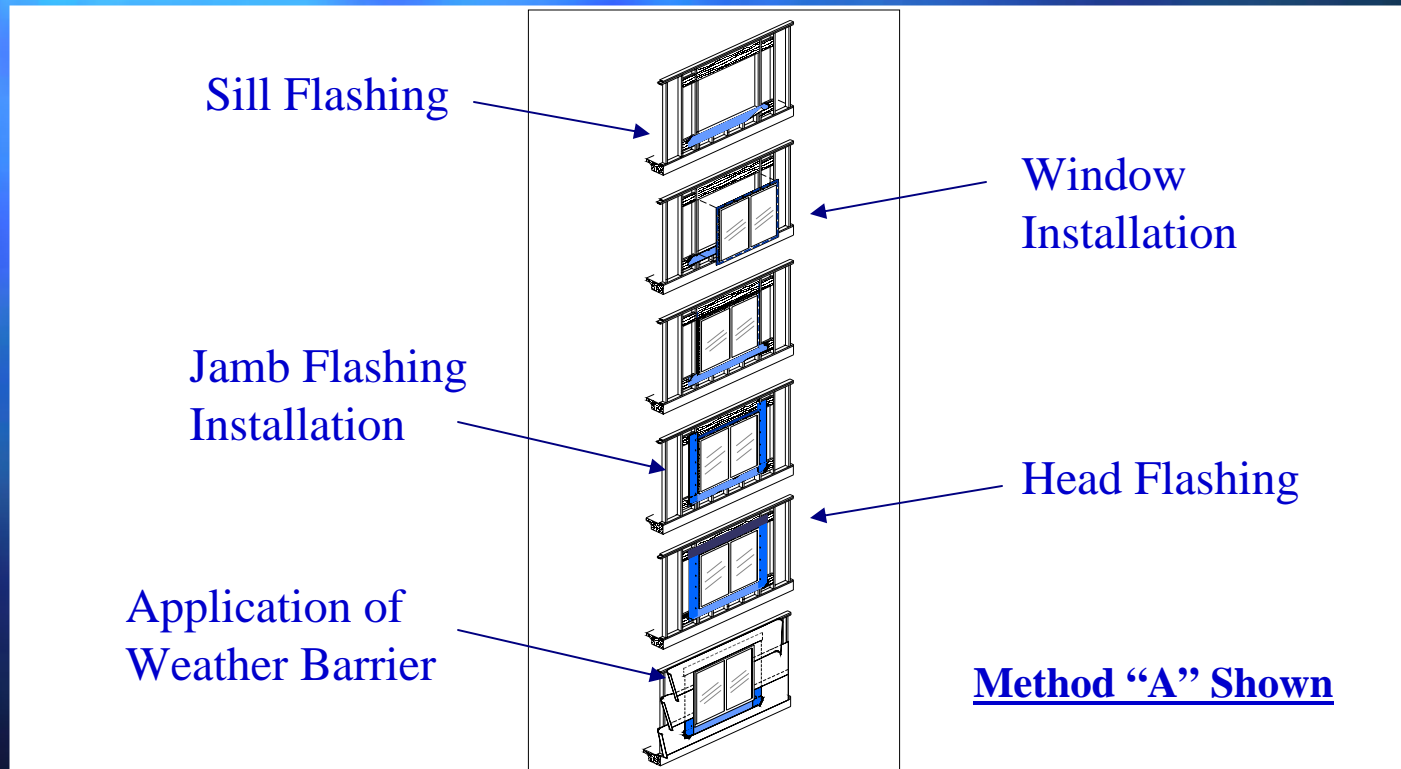

For each of the installation methods outlined for mounting flange windows.

# Details of the Training Program

Chapter 16 also covers installation details for...

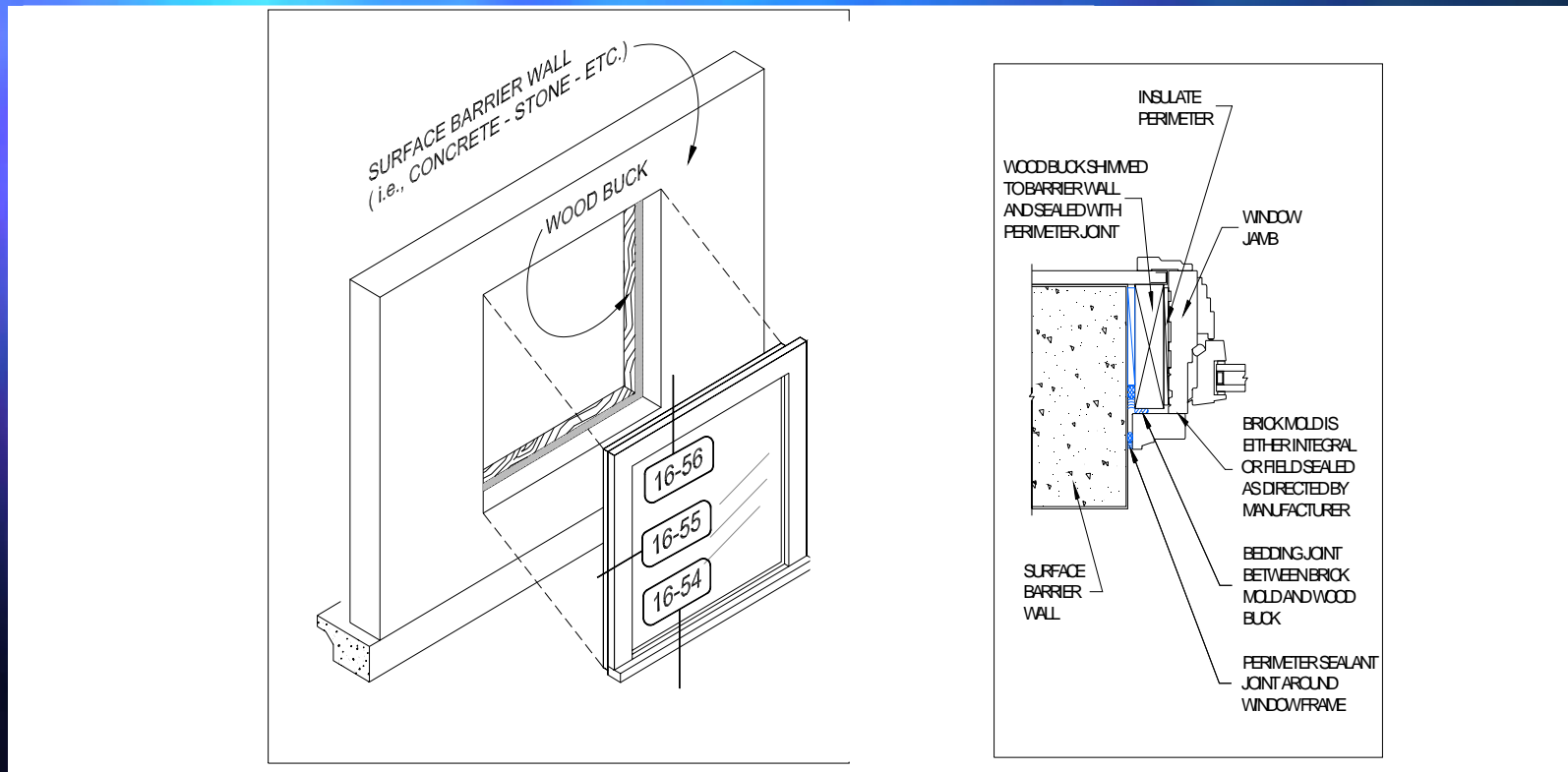

Block frame windows with and without brick mold.

# Details of the Training Program

Chapter 17 "Bay, Bow and Garden Windows" covers...

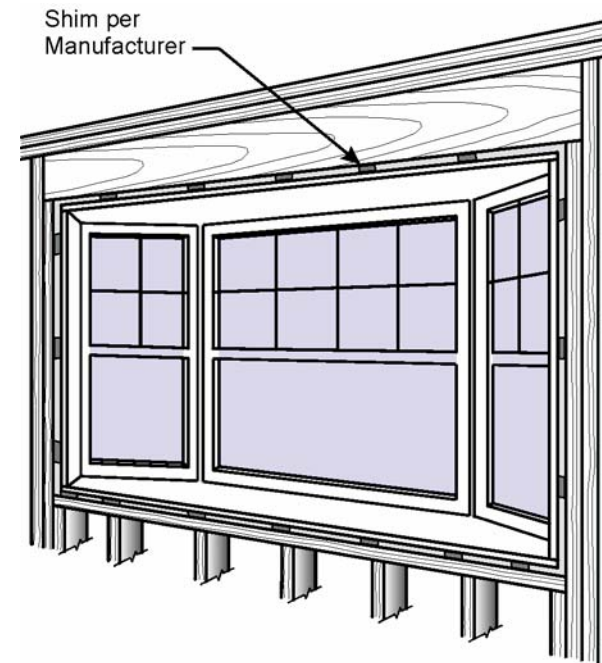
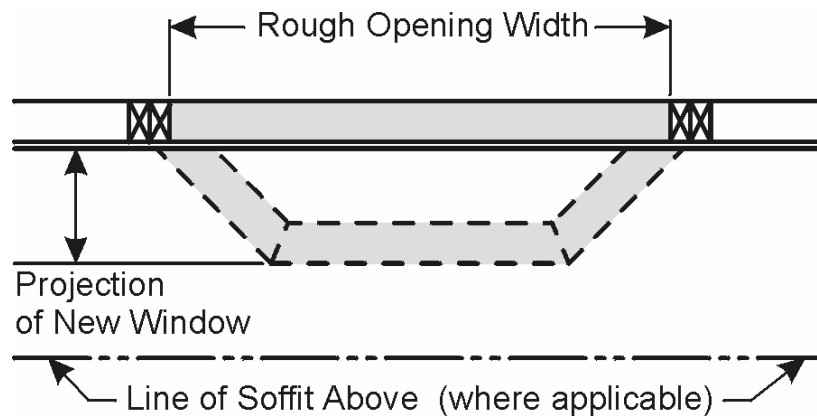

Measuring, preparation and installation of Bay, Bow and Garden Windows.

# Details of the Training Program

Chapter 18 "Combination Window Installation" covers...

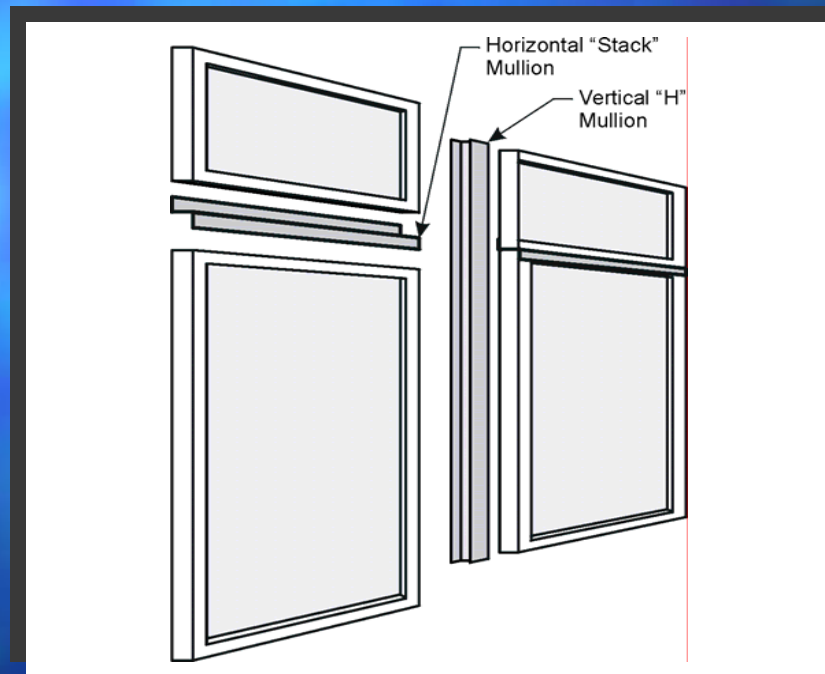

The topic of structural limitations of combination openings as well as thermal expansion and contraction and how to avoid some of the more common problems.

# Details of the Training Program

## Chapter 19 "Specially Shaped Windows" covers...

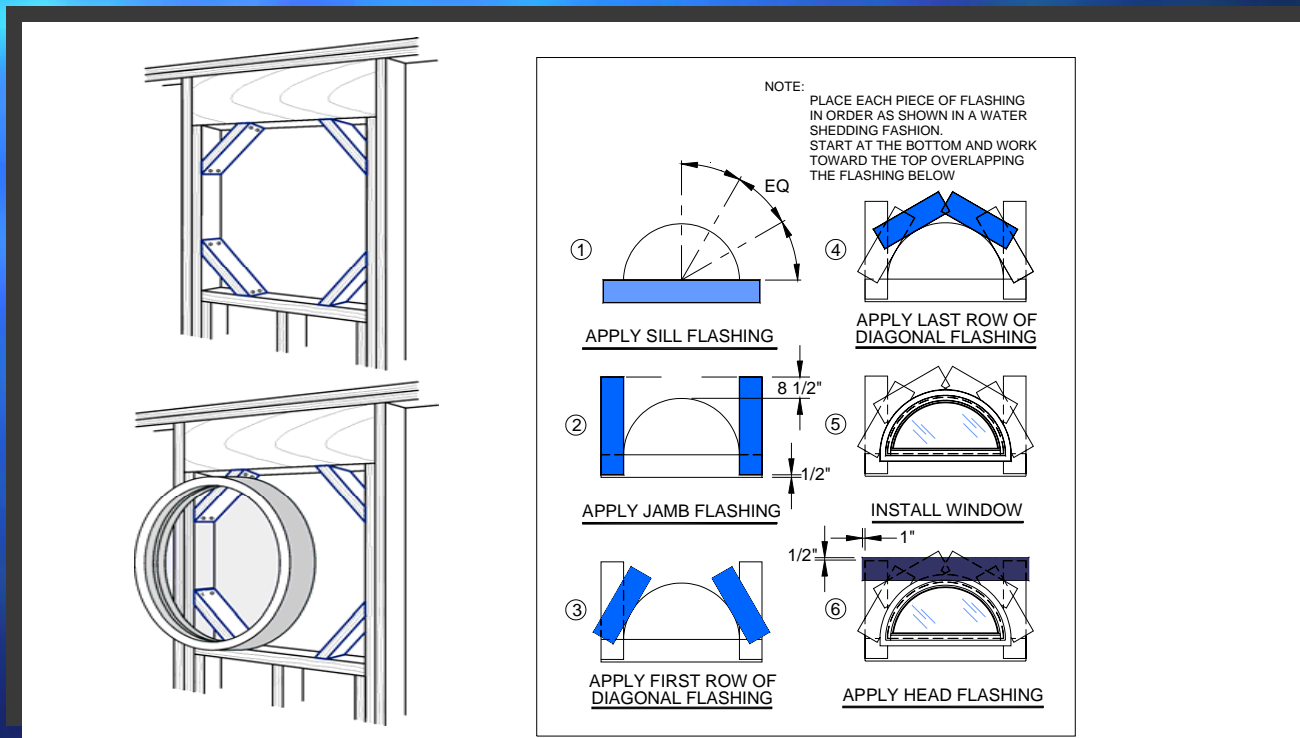

Adding structural support and how to properly flash specially shaped windows.

# Details of the Training Program

Chapter 20 "Block Frame Door Installation" covers...

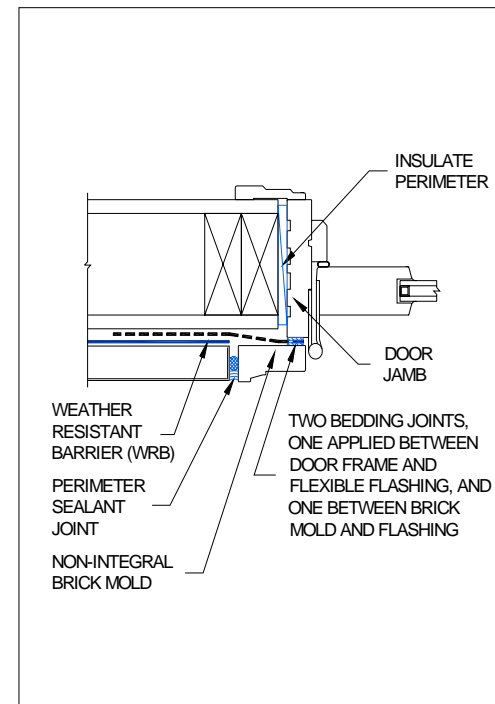
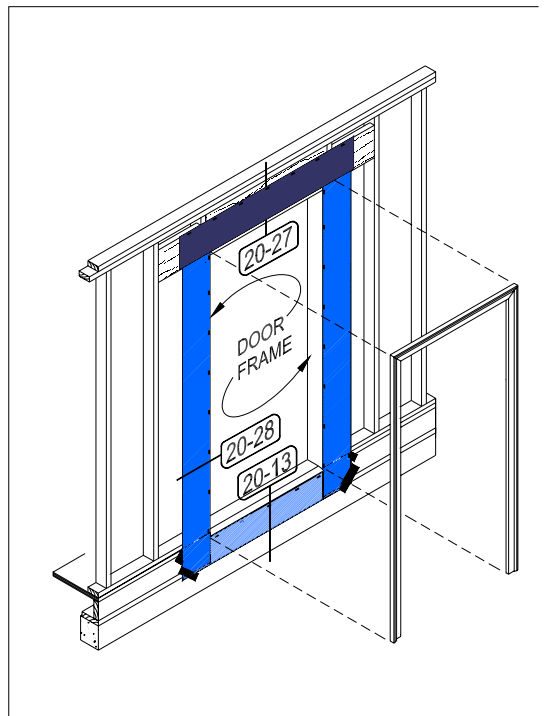

The installation of block frame doors with and without brick mold.

# Details of the Training Program

## Chapter 21 "Mounting Flange Door Installation"...

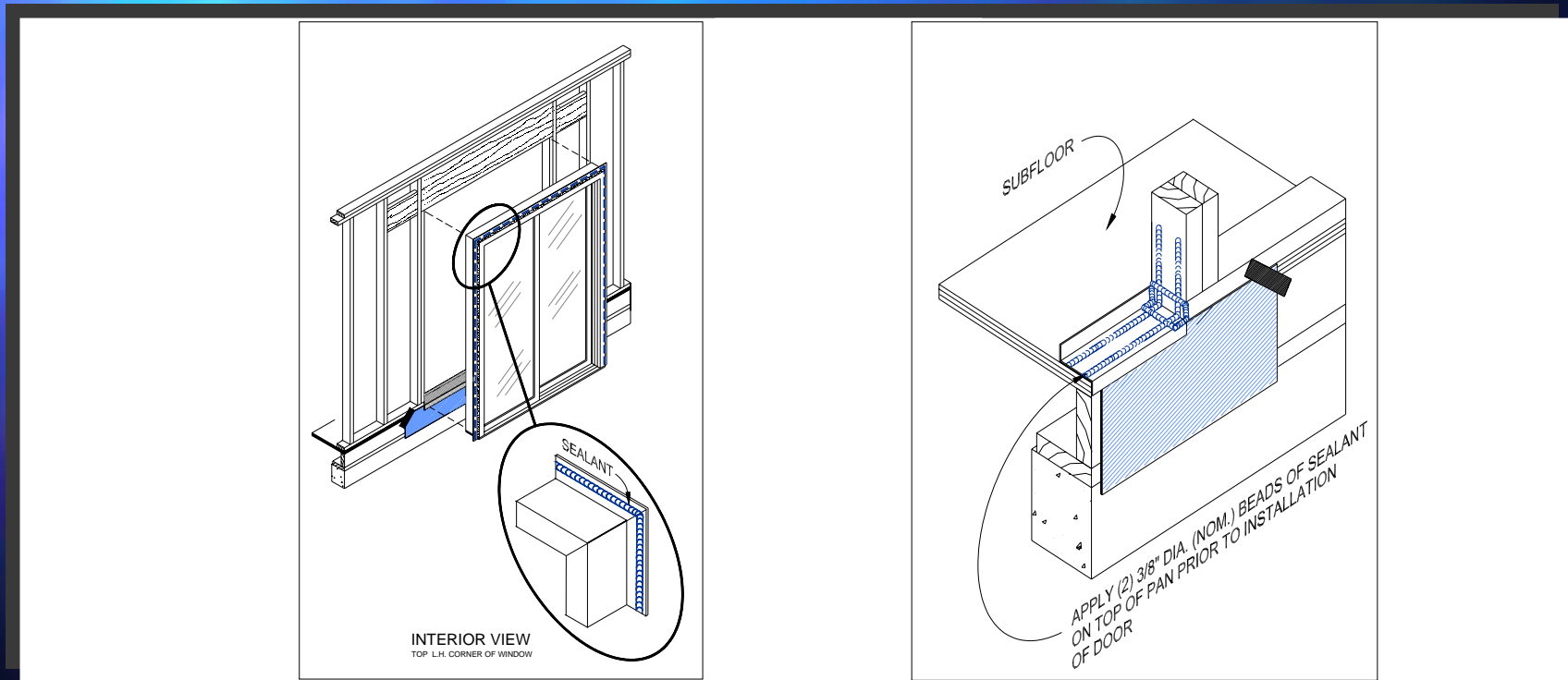

Covers installation methods for doors with mounting flanges.

# Details of the Training Program

Chapter 22 "Screen Installation" covers...

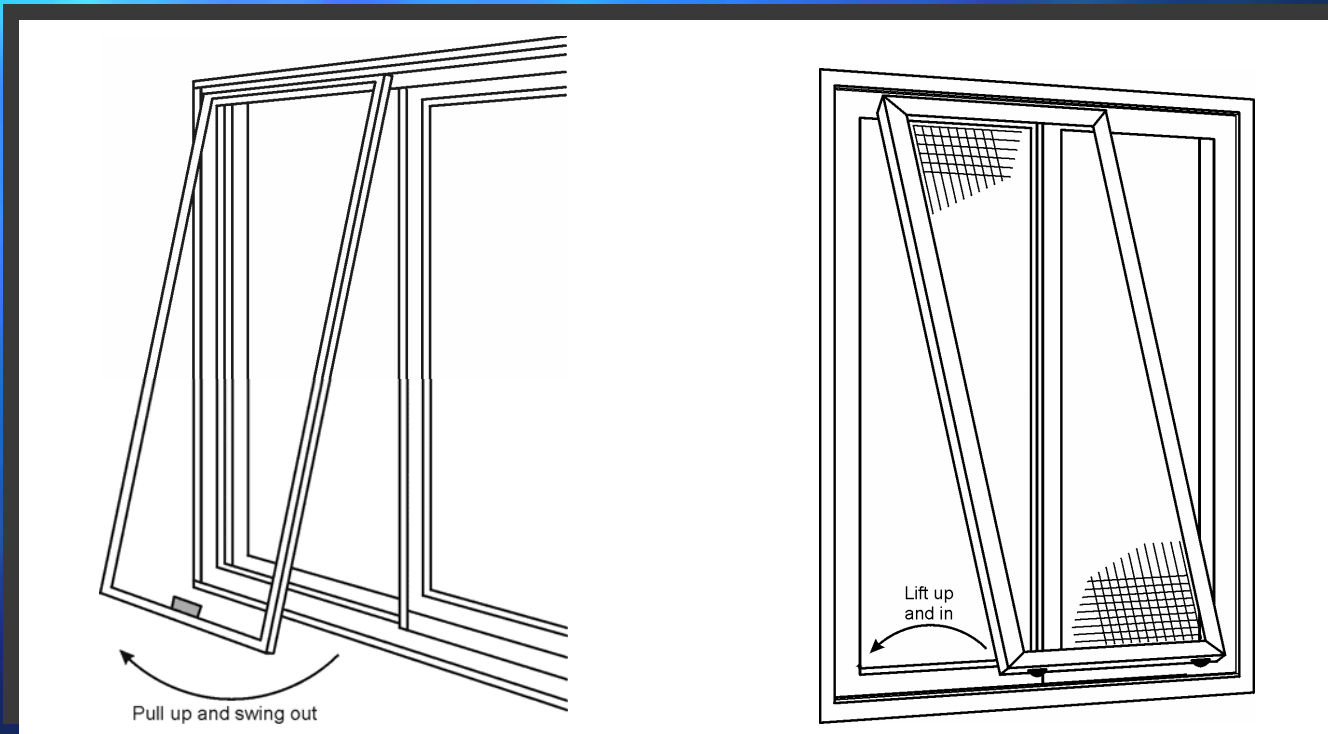

The installation and adjustment of screens for windows and doors.

# Details of the Training Program

## Instructor Training and Accreditation

- The instructor candidate goes through the two-day program for installers, one day of hands on installation, then they must teach assigned sections to the rest of the class.
- Candidates must take a final test with 168 questions. In order to pass, they must achieve a score of 90% or better.

# The Certification Process

## How does the Certification process work?

- Certification candidates take a paper/pencil test proctored by an Accredited Instructor. The test is offered after the end of the two day training session.
- Candidates taking the self study program take a test at a computer facility. We have 78 facilities set up across the country for their convenience.
- The test involves 70 multiple choice questions. Candidates must receive a 70% or better to become certified.

# The Certification Process

How does the Certification process work?

- Certification lasts for a period of 4 years. Each of the Certified InstallationMasters™ gets a photo ID Card.
- Our intent is to continue to work with ASTM to come up with additional installation methods.
- Our intent is to continually update the program and keep the installers informed about changes in the future.

# The Certification Process

## What does InstallationMasters™ Certification mean?

- InstallationMasters™ is not guaranteeing the work of the installer, nor the completeness or accuracy of their work.
- Being a Certified InstallationMaster™ means that candidates have passed an examination indicating that they have attained a specific set of knowledge skills.
- Our program teaches them the fundamentals about best installation practices. They determine how to apply that knowledge in the field.

# What are the Benefits?

---

- Fewer call-backs due to poor installation.
- Less long-term liability due to water intrusion.
- Improved energy efficiency.
- Improved owner satisfaction.



We think you'll agree...  
It's about time, and worth  
the investment!